

# **Capsule Report**

## **Managing Cyanide in Metal Finishing**

U.S. Environmental Protection Agency  
Office of Research and Development  
National Risk Management Research Laboratory  
Technology Transfer and Support Division  
Cincinnati, OH 45268

---

## **Notice**

The U.S. Environmental Protection Agency (EPA) through its Office of Research and Development funded and managed the research described here under contract number 8C-R520-NTSX to Integrated Technologies, Inc. It has been subjected to the Agency's peer and administrative review and has been approved for publication as an EPA document. Mention of trade names or commercial products does not constitute endorsement or recommendation for use.

---

## Foreword

The U.S. Environmental Protection Agency is charged by Congress with protecting the Nation's land, air, and water resources. Under a mandate of national environmental laws, the Agency strives to formulate and implement actions leading to a compatible balance between human activities and the ability of natural systems to support and nurture life. To meet this mandate, EPA's research program is providing data and technical support for solving environmental problems today and building a science knowledge base necessary to manage our ecological resources wisely, understand how pollutants affect our health, and prevent or reduce environmental risks in the future.

The National Risk Management Research Laboratory is the Agency's center for investigation of technological and management approaches for preventing and reducing risks from pollution that threatens human health and the environment. The focus of the Laboratory's research program is on methods and their cost-effectiveness for prevention and control of pollution to air, land, water, and subsurface resources; protection of water quality in public water systems; remediation of contaminated sites, sediments and ground water; prevention and control of indoor air pollution; and restoration of ecosystems. NRMRL collaborates with both public and private sector partners to foster technologies that reduce the cost of compliance and to anticipate emerging problems. NRMRL's research provides solutions to environmental problems by: developing and promoting technologies that protect and improve the environment; advancing scientific and engineering information to support regulatory and policy decisions; and providing the technical support and information transfer to ensure implementation of environmental regulations and strategies at the national, state, and community levels.

This publication has been produced as part of the Laboratory's strategic long-term research plan. It is published and made available by EPA's Office of Research and Development to assist the user community and to link researchers with their clients.

E. Timothy Oppelt, Director  
National Risk Management Research Laboratory

---

## Acknowledgments

This guide was prepared by Peter A. Gallerani, Integrated Technologies, Inc., Jeff Lord, Black Company Environmental, and Kevin Klink, CH2M Hill. Douglas Grosse, U.S. Environmental Protection Agency, Office of Research and Development, National Risk Management Research Laboratory (NRMRL), was the project officer, and performed technical review and editorial assistance. Dave Ferguson, NRMRL, served as the technical consultant.

The following people provided technical review, editorial assistance, and graphic design:

Dr. David Szlag	U.S. Environmental Protection Agency, NRMRL
Paul Shapiro	U.S. Environmental Protection Agency, Office of Research and Development, Office of Science Policy
Joseph Leonhardt	Leonhardt Plating Co.
Dr. John Dietz	University of Central Florida
Carol Legg	U.S. Environmental Protection Agency, NRMRL
John McCready	U.S. Environmental Protection Agency, NRMRL

---

## Contents

Notice .....	ii
Foreword .....	iii
Acknowledgments .....	iv
1.0 Introduction .....	1
Background .....	1
2.0 Cyanide Plating Chemistry .....	3
3.0 Cyanide Toxicity .....	5
4.0 Cyanide Safety .....	6
5.0 Wastewater Treatment of Cyanide .....	8
Alkaline Chlorination .....	8
Metal Cyanide Complexes .....	9
Oxidation of Cyanide with Hydrogen Peroxide .....	9
Oxidation of Cyanide with Ozone .....	10
Ultraviolet (UV) Oxidation .....	10
Electrochemical Oxidation of Cyanide .....	10
Thermal Oxidation .....	11
Acidification and Acid Hydrolysis .....	11
Other Cyanide Treatment .....	11
6.0 Source Reduction .....	12
Carbonate Chemistry .....	12
Other Contaminants .....	12
Recovery Technologies .....	13
Vacuum Evaporation .....	13
Reverse Osmosis .....	13
Ion Exchange .....	13
Electrowinning .....	14
7.0 Cyanide Alternatives .....	16
8.0 Cyanide Monitoring and Analysis .....	17
Wastewater Compliance Monitoring .....	17
Cyanide Analysis .....	17
"Standard Methods," Method 4500-G .....	18
EPA Method 335 Cyanide Amenable to Chlorination .....	19
ASTM D 2036 B .....	19
EPA Method OIA-1677 .....	19
9.0 Summary .....	20

---

## Contents (continued)

References .....	21
Appendices	
A. Optimizing Operating Procedures .....	22
B. Best Management Practices .....	23

---

## Tables

1. Metal and Complexed Metal Electrode Potentials .....	4
2. Cumulative Formation Constants for Cyanide Complexes .....	4
3. Toxicity of Various Cyanide Compounds .....	5
4. Cyanide Half-life Under Natural Degradation .....	6
5. Concentrations of Free Cyanide in Solutions of Various Concentrated Metal Cyanide Complexes .....	9
6. Cyanide and Non-cyanide Plating Processes .....	16

---

## Figures

1. Open process showing solution maintenance using periodic dump or bleed and countercurrent rinsing with a continuous wastewater discharge. ....	13
2. Closed-loop process showing continuous solution maintenance and rinsewater recovery with natural evaporation. ....	14
3. Closed-loop process showing continuous solution maintenance and rinsewater recovery with reverse osmosis or vacuum evaporation. ....	14
4. Open-loop process showing continuous solution maintenance and rinsewater recovery with natural evaporation and ion exchange/electrowinning. ....	15
5. Distillation apparatus for evaluating cyanide samples. ....	18
6. Flow injection analysis schematic. ....	19



## 1.0 Introduction

The purpose of this document is to provide guidance to surface finishing manufacturers, metal finishing decision makers and regulators on management practices and control technologies for managing cyanide in the workplace. This information can benefit key industry stakeholder groups for implementing “cleaner, cheaper and smarter” environmental management of cyanide in the metal finishing industry. Key stakeholder groups include the American Electroplaters and Surface Finishers Society <<http://www.aesf.org>>, the National Association of Metal Finishers <<http://www.namf.org>>, the Metal Finishing Suppliers Association <<http://www.mfsa.org>> and the USEPA. It is important to understand existing practices as well as bold innovative ideas that enhance environmental performance in the metal finishing industry. For more information on new ideas in the metal finishing program, see <<http://www.strategicgoals.org/>>.

### Background

Cyanide has been used extensively in the surface finishing industry for many years; however, it is a hazardous substance that must be handled with caution. The use of cyanide in plating and stripping solutions stems from its ability to weakly complex many metals typically used in plating. Metal deposits produced from cyanide plating solutions are finer grained than those plated from an acidic solution. In addition, cyanide-based plating solutions tend to be more tolerant of impurities than other solutions, offering preferred finishes over a wide range of conditions: (1) cyanide-based strippers are used to selectively remove plated deposits from the base metal without attacking the substrate, (2) cyanide-based electrolytic alkaline descalers are used to remove heavy scale from steel and (3) cyanide-based dips are often used before plating or after stripping processes to remove metallic smuts on the surface of parts. Cyanide-based metal finishing solutions usually operate at basic pH levels to avoid decomposition of the complexed cyanide and the formation of highly toxic hydrogen cyanide gas.

Cyanide complexes and free cyanide exist in equilibrium depending on the pH of the solution. As a rule, lowering the pH shifts the equilibrium forming hydrogen cyanide gas that can escape from the solution. Raising the pH forces a shift in the equilibrium that prevents hydrogen cyanide formation and minimizes the loss of cyanide from the plating solution. One exception is the strong cyanide complex formed with gold. The potassium gold cyanide complex is stable at acidic pH, and gold plating can effec-

tively take place from a solution with a relatively low pH. Some complexes of cyanide are highly stable, such as iron, nickel or cobalt, and these complexes can cause problems in effluent discharges, since they are stable and difficult to destroy.

Cyanide-bearing materials, solutions and wastestreams require special handling and management. Cyanide compounds are readily absorbed through the skin or lungs from dust or vapor. Fish populations are especially sensitive to cyanide, and fish kills can occur at levels less than one part per million (US EPA, 1979). Cyanide can also cause upsets at municipal wastewater treatment plants by disrupting biological treatment units. For these reasons, it is critical to limit cyanide compounds entering municipal waste treatment systems and the environment. In a typical metal-finishing facility, cyanide-bearing wastestreams are segregated from other metal-finishing wastestreams and are pretreated using alkaline chlorination prior to other wastewater treatment.

Cyanide use in metal finishing has become a focus area for governmental and non-governmental organizations. Though cyanide-related incidents in the metal finishing industry have been few, cyanide use in the industry has been significantly reduced. Many facilities have turned to non-cyanide alternatives. Non-cyanide processes have been developed for copper, cadmium, indium and zinc plating. Non-cyanide silver and gold-plating processes have also been developed but are generally not well accepted. More effective substitutes for brass, bronze, silver, gold and other less common plating processes are still being developed. Non-cyanide alkaline descaling and metal-stripping processes are common and utilize other metal complexers such as ethylene diamine triacetic acid (EDTA). Cyanide is usually replaced by strong chelating or complexing compounds, creating new process control and wastestream challenges. Furthermore, most non-cyanide replacements tend to be proprietary processes, with many of the technical process details concealed from potential users. This makes solution and rinsewater management more difficult.

Residual cyanide in metal finishing sludge has become an increasing concern for metal finishers as the disposal options for cyanide-bearing sludge are limited and costs are high. Many metal finishers have adopted advanced cyanide destruction and segregated precipitation systems to control cyanide residuals in metal finishing sludge.

Environmental, health and safety requirements, coupled with competitive pressures, have forced metal finishers to adopt better process management practices. Advances in operating practices, process control, chemical recovery and pretreatment make it possible to use cyanide without increasing risk to workers or the public. To manage cyanide efficiently, its toxicity must be understood and inadvertent exposure tightly controlled. In addition, the chemistry of the cyanide system must be controlled and monitored to prevent fugitive emissions from the system. Control technology should encompass plating process tanks, rinse tanks, recovery systems, waste treatment and air

emission control devices to enable a facility to safely and effectively use cyanide, while protecting workers from significant exposure and minimizing environmental impacts from water, solid waste and air emissions.

Many operators and decision makers inside and outside the industry assume non-cyanide processes to be environmentally and occupationally safer than cyanide processes. The issues are much more complex than that.

This report covers various aspects of cyanide chemistry, use, toxicity, problems and control.

## 2.0 Cyanide Plating Chemistry

Cyanide readily joins with a variety of metals. Bonding between the metal ion and cyanide (a ligand) occurs quite readily. Electrochemically, the formation of a metal-cyanide complex can alter the reduction potential, changing the required potential (voltage) for metal deposition to occur in plating. (Lowenheim, 1953; Swartz, 1996). Table 1 shows the shift of the electrode potential for several common plated metals when complexed with cyanide. This shift may improve plating, prevent immersion deposits from forming or shift the potential of two different species to be nearly identical. In electrolytic plating cells, the metal with the lowest potential (most negative) will typically plate first. If the electrical potentials are close, alloy plating can occur. Cyanide use in brass plating shifts the potentials of copper and zinc from a difference of greater than one volt to a difference of approximately 0.1V that allows brass plating to occur.

Each cyanide ion attaches to a metal via a coordination site and exists in equilibrium between the complexed species and free cyanide ions. When the pH of the system is lowered, free cyanide will combine with the available hydrogen ions and form hydrogen cyanide (HCN) gas that has the propensity to escape from solution. Some processes exhibit small releases of hydrogen cyanide during plating, such as acid cyanide gold plating. Many variables govern the quantity released; however, actual hydrogen cyanide measurements above the tank have shown HCN concentrations in the range of 3-5 ppm (California State University, 1990). Most cyanide plating solutions are operated at alkaline pH to prevent the potential release of HCN. Alkaline operation causes the solution to slowly absorb carbon dioxide from the air, forming carbonates. Carbonates are generally not an interference at low concentrations (below 60 g/L), but as the concentration increases, they will begin to precipitate, which can interfere with the quality of the plated deposit. Consequently, cyanide solutions, and other alkaline solutions, are generally not air-agitated since solution aeration would introduce more carbon dioxide to the system and increase the carbonate build-up rate.

Common cyanide metal complexes encountered in metal finishing are shown in Table 2. The formation constant is derived from the equilibrium expression shown, generally, in equations 1 and 2. In equation 1, metal and cyanide ions react to form a metal cyanide complex. However, in most of these types of reactions, some reactant will remain after the reaction ceases. Completeness of the reaction is measured by comparing the relative amounts of reactants and products, shown mathematically in equation 2. The greater the concentration of the reaction products, the higher the value of the formation constant.

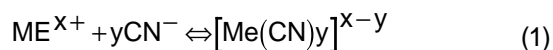

$$\frac{[ME(CN)_y]^{X-y}}{[Me^{X+}][CN^{-}]^y} = K_{eq} \quad (2)$$

An unfavorable reaction (release of HCN) exhibits a negative log of the formation constant. Table 2 shows that the stability of the respective metal cyanide complexes can vary a great deal. Iron complexes are approximately 10 to 15 orders of magnitude more stable than copper or silver complexes. Copper and cadmium form complexes where the additions of the second, third or fourth ligands do not significantly increase the solution stability, and plating can readily occur. The formation constant for gold is quite high; however, as shown in Table 1, if the electrode potential for the gold cyanide complex has been lowered significantly, plating can occur. In general, deposition appears to take place from the lowest coordinated form (Lowenheim, 1953). The formation constants for cyanide complexes show why iron cyanide as ferrocyanide or ferricyanide is difficult to destroy and why incomplete cyanide destruction is possible for a variety of metal cyanide complexes. Furthermore, complexing can greatly effect the toxicity of the resultant compound. For example, ferrocyanide is less toxic than copper cyanide, which is less toxic than sodium cyanide.

**Table 1.** Metal and Complexed Metal Electrode Potentials

Metal	Electrode Potential	Cyanide Complex	Electrode Potential
Ni <sup>+2</sup>	-0.25V	[Ni(CN) <sub>4</sub> ] <sup>-2</sup>	-0.80V
Cu <sup>+1</sup>	+0.52V	[Cu(CN) <sub>3</sub> ] <sup>-2</sup>	-1.17V
Ag <sup>+1</sup>	+0.80V	[Ag(CN) <sub>2</sub> ] <sup>-1</sup>	-0.31V
Au <sup>+1</sup>	+1.68V	[Au(CN) <sub>2</sub> ] <sup>-1</sup>	-0.67V
Zn <sup>+2</sup>	-0.76V	[Zn(CN) <sub>4</sub> ] <sup>-2</sup>	-1.28V

Source: Lange's Handbook of Chemistry 13<sup>th</sup> Ed.

**Table 2.** Cumulative Formation Constants for Cyanide Complexes

Metal	Log K <sub>1</sub>	Log K <sub>2</sub>	Log K <sub>3</sub>	Log K <sub>4</sub>	Log K <sub>6</sub>
Cadmium	5.48	10.6	15.23	18.78	
Copper (I)		24.0	28.59	30.30	
Gold (I)		38.3			
Iron (II)					35
Iron (III)					42
Mercury (II)				41.4	
Nickel				31.3	
Silver (I)		21.1	21.7	20.6	
Zinc				16.7	

Source: Lange's Handbook of Chemistry 13<sup>th</sup> Ed.

### 3.0 Cyanide Toxicity

Many forms of cyanide are toxic to humans. Toxicity can be attributed to interactions with low pH (acidic) solutions and some biological systems to produce hydrogen cyanide. Hydrogen cyanide has a time-weighted average exposure limit of 10 ppm for 8 hours. (Sax, 1989). Most of the inorganic salts have exposure limits of a few parts per million. Exposure can occur by absorption through the skin, by inhalation of dusts or gas, or by ingestion. Exposure to minor amounts of cyanide on the skin can result in dermatitis. Certain species of fish are extremely sensitive and can be killed by low levels of cyanide (US EPA, 1979). Bluegill, salmon and trout are killed by levels slightly over 0.1 ppm cyanide. Compound levels below 0.1 ppm can functionally effect metabolic and reproductive cycles. Cyanide levels that kill fish often do not adversely impact lower aquatic organisms like crustaceans and mussels. Toxicity may extend to microorganisms that digest sewage and sludge.

Chlorination can result in the formation and release of cyanogen chloride, with the exposure limit for cyanogen chloride more than an order of magnitude lower than for cyanide.

Cyanide exposure in metal-finishing shops usually occurs via skin absorption and inhalation. Poor personal hygiene or improper use of personal protective equipment (PPE) can lead to ingestion. Careful cleaning and storage of tools and PPE are necessary to avoid potential exposure to cyanide. Handling reagents, solutions and waste can lead to skin absorption. Exposure to hydrogen cyanide and/or related gases resulting from plating operations present an inhalation hazard. Cyanide emissions from cadmium, copper and gold cyanide plating are known to release hydrogen cyanide gas at low levels during the plating cycle (Electroplating, 1996). Sound process control practices limit gas emissions from process solutions and wastewater treatment operations. Ventilation is recommended for all cyanide processes. Human exposure toxicity is typically acute rather than chronic. Exceeding exposure levels can result in disorientation, dizziness and nausea. Cyanide poisoning occurs by blocking blood oxygen transfer, which can result in death by asphyxia. Table 3 lists key exposure data for cyanide compounds commonly used in metal finishing.

**Table 3.** Toxicity of Various Cyanide Compounds

Compound	Formula	Physical Form	TLV	LD <sub>50</sub>
Hydrogen cyanide	HCN	Gas	5 mg/m <sup>3</sup>	1 mg/kg human
Potassium cyanide	KCN	Solid	5 mg/m <sup>3</sup>	10 mg/kg rat 2.85 mg/kg human
Sodium cyanide	NaCN	Solid	5 mg/m <sup>3</sup>	6.44 mg/kg rat 2.85 mg/kg human
Cyanogen chloride	CNCl	Gas	0.3 ppm	
Sodium cyanate	NaCNO	Solid		260 mg/kg mice
Potassium cyanate	KCNO	Solid		320 mg/kg mice
Potassium ferricyanide	K <sub>3</sub> [Fe(CN) <sub>6</sub> ]	Solid		1600 mg/kg rat

Sources: (Sax, Merck)

TLV threshold limit value is the time time-weighted average concentration for an 8-hour workday and 40-hour workweek to which a worker may be repeatedly exposed without adverse effect.

LD<sub>50</sub> lethal dose to 50% of a specified population.

## 4.0 Cyanide Safety

The hazards associated with cyanide use cannot be minimized; however, the risks can be reduced through safe handling practices. It is important to recognize potential hazards and routes of exposure. Process operators, wastewater treatment operators, maintenance personnel, laboratory technicians, engineers, shipping and receiving clerks and facility visitors can all be exposed to cyanide in different ways and degrees. Cyanide exposure can occur through contact with solutions, rinsewater, wastewater, concentrated wastes, sludge, raw materials, fumes, mists and contaminated materials and equipment. Contaminated materials and equipment include filtration media, drums, buckets, tanks, pumps, hoses, mixers, piping, ductwork, electrodes, etc. Cyanide safety requires the development and communication of procedures for the safe handling of cyanide reagents and residuals. Cyanide safety procedures should include instructions for chemical storage, containment, piping, transportation, handling, use, protective equipment, personal hygiene, monitoring and emergency contingencies. All personnel who are exposed to cyanide, including contractors and visitors, should receive appropriate training.

Managing cyanide safely requires effective segregation of cyanide solutions, rinses, wastestreams, sludge, raw materials and other cyanide containing materials from acids and other non-cyanide materials. The accidental mixing of acids with cyanide causes a reaction that can quickly release dangerous amounts of hydrogen cyanide gas. Cyanide solutions (with the exception of gold plating) must be maintained in an alkaline condition since even mildly acidic conditions allow hydrogen cyanide gas to form and escape. In addition, all sources of cyanide in the facility must be identified and controlled. Many surface finishing process solutions can contain cyanide, including cleaners, stripping solutions and chromating treatments.

Safe cyanide handling requires careful attention to personal hygiene. Workers must avoid skin and eye contact through the use of protective clothing and equipment. Workers should keep a spare set of clothing at work in case clothing becomes contaminated with cyanide. Ideally, workers should shower and change clothes at the end of the work shift and workers should always wash up before handling food or other items. Exposure to small amounts of cyanide over a period of time can result in dermatitis. Dermatitis, if left untreated, can develop into sores and lead to infection, and provides an easy entry point for cyanide into the body.

Handling of solids should be limited to trained personnel, and solutions should be prepared in areas with adequate ventilation to prevent exposure to dust. Ventilation systems designed for use in conjunction with solids handling should include dust collection. The appropriate dust collection technique will vary, depending on the quantity handled, and may include the use of dust masks for further protection.

Remote exhaust systems on process and waste treatment tanks capture hazardous mists and fumes. Wet process ventilation may also require a scrubber to control air emissions. Air agitation of cyanide solutions should be avoided because it causes misting. Air agitation should also be avoided since carbon dioxide in the air is acidic enough to liberate hydrogen cyanide. Air agitation also enhances carbonate build-up by absorption of carbon dioxide in the alkaline solution. Table 4 provides the half-life of cyanide at various temperatures.

Alkaline chlorination treats cyanide wastewater. During this process, cyanide destruction occurs in two steps. Maintaining the proper pH is essential to avoid the gaseous release of chlorine and cyanogen chloride and the formation of hydrogen cyanide. Oxidation-reduction potential (ORP) devices measuring residual chlorine determine treatment endpoints. Complete destruction of cyanide requires adequate reaction time and excess chlorine. A residual concentration of free chlorine will be present after treatment, and it is important that the residual be reduced. An

**Table 4.** Cyanide Half-life Under Natural Degradation

Metal Cyanide	Half-life, hours			
	pH 7		pH 10.5	
	4°C	20°C	4°C	20°C
Zn	30	14	700	300
Cu	400	130	10,000	3200
Ni	1,700	700	13,600	5800
Fe	22,000	7,700	23,000	71,000

Source: Environment Canada

excessive concentration of chlorine can result in the release of chlorine gas during pH adjustment. Other sources of  $\text{Cl}_2$ , such as sodium hypochlorite, may be safer.

Some facilities have installed continuous monitors to ensure that hydrogen cyanide, cyanogen chloride and chlorine exposure are kept well below minimal levels.

Where HCN limits are usually expressed in  $\text{mg}/\text{m}^3$ , cyanide air emissions can be estimated on the basis of equi-

librium levels of cyanide in the air over solutions at various temperature and pH values from the following (Menne, 1997):

$$[\text{HCN}]_{\text{air}} = [(1470/T)e^{(9.275-2992/T)}]/[1+10^{(\text{pH}-9.3)}] \quad (3)$$

where

HCN = mg HCN/ $\text{m}^3$  air per ppm NaCN in solution.  
T = temperature, Kelvin.

## 5.0 Wastewater Treatment of Cyanide

Cyanide-bearing wastewaters usually require segregation of cyanide wastestreams from other wastestreams. Pretreatment of cyanide prior to other treatment operations prevents the formation of HCN in untreated wastewater or primary treatment operations. Segregation also prevents CN complexing of metals from non-cyanide-bearing wastewater and minimizes overall wastewater treatment costs. Cyanide pretreatment typically involves alkaline chlorination; however, acid hydrolysis, UV oxidation, electrolytic decomposition and thermal destruction are also used. Concentrated cyanide wastestreams are typically treated using electrolytic decomposition or thermal destruction. Concentrated wastestreams are often bled into more dilute wastestreams at a prescribed rate to facilitate treatment with conventional technology.

Many oxidants are available for cyanide destruction including these: chlorine gas, sodium hypochlorite, calcium hypochlorite, ozone and hydrogen peroxide. Cyanide destruction using chlorine gas and sodium hypochlorite far exceeds the use of other oxidants in industrial practice. The effectiveness of cyanide destruction is usually measured by the concentration of total residual cyanide remaining in the wastestream. Total cyanide has two components: cyanide amenable to chlorination and non-amenable cyanide. Cyanide amenable to chlorination can be destroyed using conventional alkaline chlorination.

### **Alkaline Chlorination**

Alkaline chlorination occurs at basic pH using hypochlorite. Alkaline chlorination destroys cyanide in a two-step process by oxidizing cyanide first to cyanate and second to carbon dioxide and nitrogen. Hypochlorite is produced by sodium contacting chlorine with sodium hydroxide (equation 4). The reaction is reversible, with some free chlorine left in solution. In cyanide destruction, chlorine reacts with cyanide to form cyanogen chloride (equation 5). The cyanogen chloride reacts with available hydroxide to form cyanate (equation 6). Cyanogen chloride is a gas with a very high solubility in water (25 liters gas per liter of water) and does not readily escape from solution. (Hartinger, 1994)

Then the cyanate (equation 7) is converted to the more innocuous carbon dioxide and nitrogen.

In the first step, the reaction vessel is operated at a pH between 10 and 12 to optimize the conversion of cyanide to cyanate. Increasing the pH from 10 by one unit increases the reaction rate ten-fold, to a pH of 12, where no additional change in rate is observed (Hartinger, 1994). During the first step, cyanogen chloride, which is highly toxic, is formed as an intermediate. If the pH is maintained in the prescribed range and sufficient hypochlorite is available, the intermediate cyanogen chloride is converted immediately to cyanate, preventing its release from solution. The oxidation of cyanide to cyanate reduces the toxicity of the compound significantly. Although this first step typically requires a reaction time of between 1 and 20 minutes at a  $\text{pH} \geq 10$ , a 40-60 minute retention time is required for continuous-flow systems. Longer retention times (up to 12 hours) are required for certain metal cyanide complexes. Temperature for batch reactors can also affect the reaction rate significantly where at 26°C and pH 10 the rate is as fast as at pH 11.5 and 18°C (Hartinger, 1994). The vapor pressure of cyanogen chloride increases rapidly with temperature, and operation of cyanide treatment reactors above 50°C is not recommended. In addition to controlling pH, the ORP should be calibrated at +325 to +400 millivolts during the first stage reaction to maintain the proper chlorine dose.

The second step reaction involves conversion of cyanate to carbon dioxide (or carbonate) and nitrogen. During the second step, the pH is reduced to 8.5. It should never fall below pH 8.0 since cyanogen chloride may be released should the first-stage reaction be incomplete. The second-stage reaction rate is also pH dependent, starting rapidly and decreasing speed as the pH is lowered to 8.5 where no further rate increase is observed. This second step requires a reaction time of between 30 and 60 minutes at pH 8.5. The ORP should be controlled at +600 (typical) to +800 millivolts during the second stage reaction.

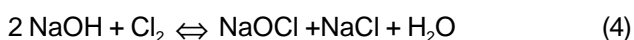



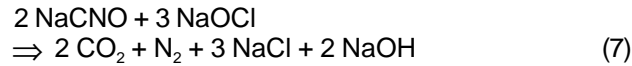
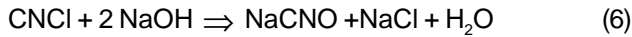
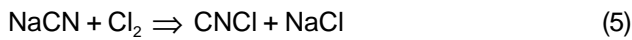

Eventually, cyanide destruction results from the reaction of cyanate with hypochlorite (equation 7) forming nitrogen, carbon dioxide and regenerated sodium hydroxide. The combined reactions of equations 5 and 6 in the formation of cyanate from cyanide occur very rapidly. The final destruction represented by equation 7 occurs more slowly. Cyanate will slowly hydrolyze to form ammoniacal species and carbon dioxide in the absence of hypochlorite (equation 8). Proper contact time in the reaction vessel is critical to ensure that complete conversion to carbon dioxide and nitrogen has occurred.

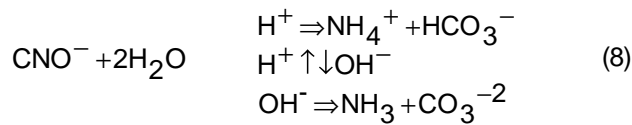

Interference with this reaction can occur in the presence of large concentrations of certain metal cyanide complexes (i.e., ferro-ferricyanide complexes). Each metal has a dissociation constant (Table 5), and very stable complexes such as the iron cyanide complexes will remain largely intact because the cyanide is not free to react. Consequently, alkaline chlorination is not effective in destroying iron cyanide complexes. Alkaline chlorination of nickel cyanide requires excess chlorine and additional retention time due to the competing reaction that forms black nickelic trioxide (Ni<sub>2</sub>O<sub>3</sub>).

### Metal Cyanide Complexes

Destruction of metal cyanide complexes is dependent upon the dissociation constant. Table 5 provides a summary of these values.

Metal cyanide dissociation is summarized by the following equation:

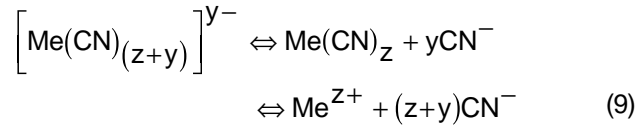

Destruction of the cyanide complexes containing cadmium, copper and zinc are readily destroyed with alkaline chlorination. Cyanide complexes containing cobalt, iron, gold, nickel and silver require alternative treatment techniques. The highly stable ferrocyanide complex reacts with chlorine only to the extent that the Fe<sup>2+</sup> ion is oxidized to Fe<sup>3+</sup> with the slightly less stable ferricyanide complex generated. Iron cyanide complexes are not amenable to chlorination and are considered relatively non-toxic. Destruction of complexed nickel cyanide through alkaline chlorination requires much higher chlorine dosing (up to 10 times the stoichiometric dose) and much longer retention times (up to 12 hours). Kinetic rather than thermodynamic factors may explain the slow oxidation rate of the nickel cyanide complex, since the dissociation constant for nickel replicates the values for copper, which is easily oxidized. The process will also result in precipitation of black hydrated nickel oxide.

The silver cyanide complex is destructible with alkaline chlorination; however, due to its very small dissociation constant, the reaction is very slow.

### Oxidation of Cyanide with Hydrogen Peroxide

Hydrogen peroxide provides another alternative in treating wastewaters containing cyanide. In a reactor-based system, hydrogen peroxide has an electrode potential of +0.878 V in alkaline solutions, which can be used as an oxidizer for cyanide. Cyanide is oxidized to cyanate and hydrogen peroxide is reduced to water per the following equation:

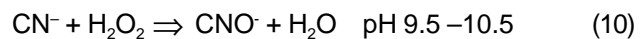

**Table 5.** Concentrations of Free Cyanide in Solutions of Various Concentrated Metal Cyanide Complexes

Metal Cyanide Complex	Dissociation Constant	mg/L Free CN in Solution at Various Total CN Concentrations			
		Total Cyanide 10 mg/L	Total Cyanide 100 mg/L	Total Cyanide 1000 mg/L	Total Cyanide 100,000 mg/L
[Hg(CN) <sub>4</sub> ] <sup>2-</sup>	4 × 10 <sup>-42</sup>	0.00003	0.000045	0.00007	0.00018
[Ag(CN) <sub>2</sub> ] <sup>-</sup>	1 × 10 <sup>-21</sup>	0.0002	0.0004	0.0009	0.004
[Fe(CN) <sub>6</sub> ] <sup>3-</sup>	1 × 10 <sup>-36</sup>	0.061	0.085	0.117	0.227
[Ni(CN) <sub>4</sub> ] <sup>2-</sup>	1 × 10 <sup>-22</sup>	0.215	0.340	0.54	1.324
[Cu(CN) <sub>4</sub> ] <sup>3-</sup>	1 × 10 <sup>-22</sup>	0.215	0.340	0.54	1.324
[Zn(CN) <sub>4</sub> ] <sup>2-</sup>	1.3 × 10 <sup>-17</sup>	2.26	3.59	5.68	14.28
[Cd(CN) <sub>4</sub> ] <sup>2-</sup>	1.4 × 10 <sup>-17</sup>	2.30	3.64	5.77	14.49

Source: *Handbook of Effluent Treatment and Recycling for Metal Finishing*, 2<sup>nd</sup> Edition, Ludwig Hartinger



The cyanide oxidation rate is dependent on the cyanide concentration, excess hydrogen peroxide concentration and temperature. Introducing catalysts can also play an important role. For example, copper can greatly increase the oxidation rate. However, copper reacts with ammonia to form a tetrammino copper complex (Hartinger, 1994). The cyanate is not further oxidized to carbon dioxide and nitrogen but is instead hydrolyzed to form ammonia and ammonium ions. The reaction is very slow at alkaline pH and increases as pH decreases.

### **Oxidation of Cyanide with Ozone**

Another oxidizer which has shown potential in oxidizing cyanide is ozone. Ozone, with an electrode potential of +1.24 V in alkaline solutions, is one of the most powerful oxidizing agents known. Cyanide oxidation with ozone is a two-step reaction similar to alkaline chlorination. Cyanide is oxidized to cyanate, with ozone reduced to oxygen per the following equation:



Then cyanate is hydrolyzed, in the presence of excess ozone, to bicarbonate and nitrogen and oxidized per the following reaction:

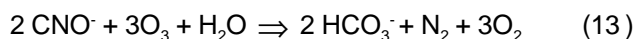

The reaction time for complete cyanide oxidation is rapid in a reactor system with 10- to 30-minute retention times being typical. The second-stage reaction is much slower than the first-stage reaction. The reaction is typically carried out in the pH range of 10-12 where the reaction rate is relatively constant. Temperature does not influence the reaction rate significantly.

The metal cyanide complexes of cadmium, copper, nickel, zinc and silver are readily destroyed with ozone. The presence of copper and nickel provide a significant catalytic effect in the stage one reaction but can reduce the rate of the stage two reaction (oxidation of cyanate). Iron, gold and cobalt complexes are very stable and are only partially oxidized, unless a suitable catalyst is added. Ultraviolet light (UV oxidation), in combination with ozone, can provide complete oxidation of these complexes.

### **Ultraviolet (UV) Oxidation**

UV light causes metal complexes such as ferricyanide and ferrocyanide to partially dissociate. UV oxidation, in combination with hydrogen peroxide or ozone, can completely oxidize all metal cyanide complexes. UV oxidation is limited to relatively clear solutions, since wastestreams are passed through a light-transmitting chamber and exposed to intense UV light. UV in combination with hydrogen peroxide results in the formation of OH· radicals, which are strong oxidizing agents capable of oxidizing iron cyanide complexes. Suitable light sources emit in the range of 200 to 280 nanometers (nm). Hydrogen peroxide and

ozone will absorb in this band. A major advantage of UV/peroxide and UV/ozone oxidation is that no undesirable byproducts (e.g., ammonia) are generated. UV oxidation has also been used in conjunction with Fenton's reagent and titanium dioxide.

The following equations summarize the reaction of hydrogen peroxide and ozone in the presence of UV light.

*Hydrogen peroxide:*

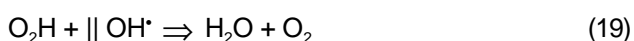
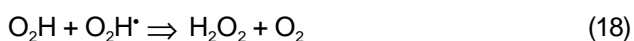
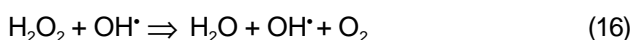
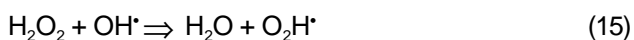

*Ozone:*



### **Electrochemical Oxidation of Cyanide**

Cyanide can be oxidized electrochemically (anodically) in chloride-based solutions. This is one of the most effective treatments for concentrated cyanide wastestreams. The reaction involves the formation of chlorine gas that dissolves in alkaline solution to form sodium hypochlorite, as shown in equation 22:

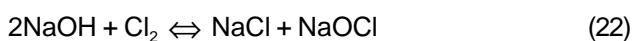

During cyanide oxidation, hypochlorite reacts with the cyanide to produce cyanate and chloride. The chloride is oxidized anodically to form hypochlorite in a closed loop.

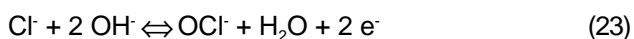

Cyanide can also be oxidized anodically without chloride, although the reaction is very slow. The theoretical energy requirement is 2.06 amp-hr per kg of cyanide. At a cell voltage of 2-4 volts, this would correspond to 4.1 to 8.2 kWh/kg of cyanide (Hartinger, 1994). The anodic reactions are shown in equations below. Electron loss leads to the formation of the unstable dicyanogen radical that immediately hydrolyzes to cyanate. The reaction is enhanced at higher temperatures (125°-200°F) with ammonia produced as an additional byproduct (Patterson, 1985).

Anode reactions:

#### Cyanide

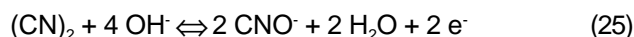

#### Hydroxide

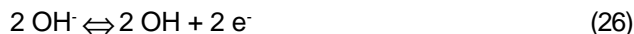

Anode materials include graphite, platinized titanium, lithium platinite and nickel. Anodic oxidation without chloride is highly dependent on anode materials. Dicyanogen formation improves progressively as steel is replaced by platinum, which is replaced by carbon and, ultimately, nickel. Electrochemical oxidation becomes uneconomical at cyanide concentrations below several hundred ppm. In this case, conventional alkaline chlorination or other treatment procedures are used for final treatment (Patterson, 1985).

### Thermal Oxidation

Thermal oxidation is another alternative for destroying cyanide. Thermal destruction of cyanide can be accomplished through either high temperature hydrolysis or combustion. At temperatures between 140°C and 200°C and a pH of 8, cyanide hydrolyzes quite rapidly to produce formate and ammonia (Hartinger, 1994). Pressures up to 100 bar are required, but the process can effectively treat wastestreams over a wide concentration range and is applicable to both rinsewater and concentrated solutions.

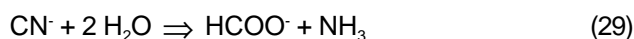

In the presence of nitrates, formate and ammonia can be destroyed in another tube reactor at 150°C, according to the following equations:

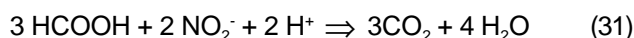
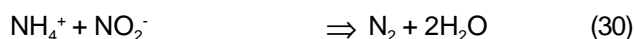

### Acidification and Acid Hydrolysis

Direct acidification of cyanide wastestreams was once a relatively common treatment. Cyanide is acidified in a sealed reactor that is vented to the atmosphere through an air emission control system. Cyanide is converted to gaseous hydrogen cyanide, treated, vented and dispersed.

Acid hydrolysis of cyanates is still commonly used, following a first stage cyanide oxidation process. At pH 2 the

reaction proceeds rapidly, while at pH 7 cyanate may remain stable for weeks (Eilbeck, 1987). This treatment process requires specially designed reactors to assure that HCN is properly vented and controlled.

The hydrolysis mechanisms are as follows:

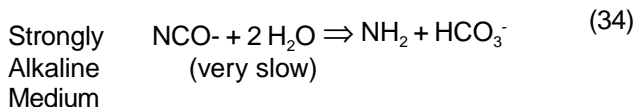
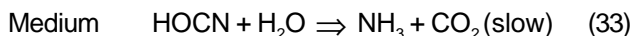
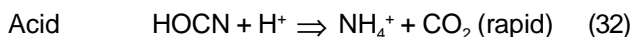

### Other Cyanide Treatment

Additional cyanide treatment processes, which have been proposed or used in limited practice, include the following:

- Cyanide Precipitation with Ferrous Salts (Hartinger, 1994)
- Cyanide Adsorption on Catalyzed Activated Carbon (Patterson, 1985)
- Kastone Process (Patterson, 1985)
- Cyanide Destruction with Mono-Peroxy Sulfuric Acid or Caro's Acid (Eilbeck, 1987; Hartinger, 1994)
- Cyanide Destruction with Oxygen (Hartinger, 1994)
- Cyanide Destruction with Aldehydes (Eilbeck, 1987)
- Cyanide Destruction with SO<sub>2</sub>/Air (Inco, 1993)
- Cyanide Destruction with Fenton's Reagent (Eilbeck, 1987)

Proponents of cyanide destruction have also proposed using bacteria, enzymes and natural clay.

Cyanide treatment systems are usually designed to destroy cyanide in a pretreatment step. Treated wastewater is then directed to secondary treatment steps, which could include additional chemical treatment and/or metal precipitation. Another alternative is to install a precipitation step immediately following cyanide destruction so that cyanide treatment may include solids removal. This added step can reduce the concentration of complexed iron or nickel and effectively reduces cyanide levels in the wastewater discharge (Martin, 1992). Although this approach may optimize total cyanide removal, it will also increase the capital and operating costs of the wastewater treatment system. Identifying additional sources of cyanide and ensuring that these sources are routed through the cyanide destruction system requires a thorough analysis of all solution chemistries.

## 6.0 Source Reduction

Cyanide plating processes can be operated effectively on a closed-loop or modified closed-loop basis using countercurrent rinsing and evaporative recovery techniques. Some cyanide-based processes must be operated at higher than normal operating temperatures to maximize bath evaporation and facilitate drag-out recovery. Many of these processes operate at ambient temperature ranging from 60 to 100°F. Recovery opportunities can be dramatically improved by operating in this temperature range. The impact of higher operating temperatures can be offset by adjusting the cyanide to metal ratio or by decreasing bath concentration. Reduced bath concentration not only reduces the mass drag-out but may also reduce the volumetric drag-out due to reduced solution viscosity. Vacuum evaporation, reverse osmosis and ion exchange can extend the application range of basic source reduction techniques. Drag-out (or rinsewater) recovery can reduce operating costs through reduced material purchases, reduced wastewater treatment costs and water usage. Drag-out recovery also eliminates the principal contaminant purge as contaminants are recovered with valuable materials.

Effective solution maintenance is important for high-quality surface finishing, especially in closed-loop processing. Solution maintenance requires basic operating procedures, including filtration to control particulates and treatment to control organics, carbonates and metallic impurities. Cyanide will slowly hydrolyze, producing ammonia and the formate ion. Ammonia will readily escape the alkaline solution, and formate is generally non-interfering. Controlling carbonates is probably the most challenging maintenance problem encountered in cyanide-based solutions.

### **Carbonate Chemistry**

Most cyanide baths are alkaline resulting from the hydrolysis of sodium and potassium cyanide, liberating sodium hydroxide (NaOH) or potassium hydroxide (KOH) and hydrocyanic acid (HCN). Most cyanide baths contain carbonates of sodium or potassium that are largely a result of the adsorption of carbon dioxide from the air and the eventual liberation of hydrocyanic acid. This reaction is accelerated by aeration of the solution and retarded by the addition of free hydroxide.

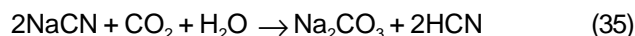

Another source of carbonate is through oxidation of cyanide. This reaction is accelerated with the use of insoluble

anodes. An intermediate product, sodium cyanate (NaCNO), may be formed.

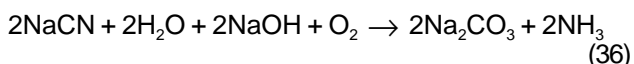

Cyanide may also decompose at high temperatures in nearly neutral solutions. This could occur with rinsewater in an atmospheric evaporator. The formic acid or sodium formate may then be oxidized to carbonate.

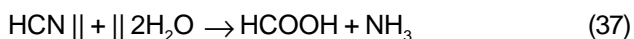

Carbonates can contaminate cyanide plating baths when they exceed their solubility and begin to precipitate in solution, causing rough plating. Solution temperature is an important variable, since the solubility of carbonates is temperature dependent. Carbonate crystals can also be introduced into the metal deposit. In addition, bath conductivity, current efficiency and throwing power decrease with increased carbonate concentration. Carbonates can be controlled within an acceptable range (2 to 8 ounces/gallon) through crystallization or chemical precipitation. Either process can be operated in a batch or continuous mode. Continuous treatment systems usually operate on a slipstream and batch processes require a separate tank. Both processes require separation of treated solutions from the resulting solids (sludge or crystals).

Solution agitation is necessary in cyanide-based process solutions to assure good mixing and allow for operation at higher current densities. Solution agitation is provided by a mechanical mixer or through solution pumping. Air agitation should be avoided, since aeration will increase carbonate build-up. Similarly, atmospheric evaporators are not normally used in cyanide-based processes, since significant aeration of the circulated solution or rinsewater increases carbonate build-up.

### **Other Contaminants**

Other cyanide-based process solution contaminants are organics, metals and chlorides. Organic contaminants are typically removed from solution with activated carbon. Metal contaminants can be removed chemically or electrolytically. For example, sodium polysulfide is used to precipitate zinc, cadmium and lead. Zinc dust is used to remove copper by displacement. Hexavalent chromium can be electrolytically reduced to trivalent chromium and plated out using high-current density, low-efficiency dummy plating.

Tin and copper can be plated out with low-current density, high-efficiency dummy plating. Chloride can also cause problems in cyanide plating processes by attacking (etching) steel anodes or anode baskets to produce dissolved iron. Rinsing in straightforward processes should be controlled to avoid drag-in of chlorides, iron and other contaminants from processes (such as pickling solutions).

Countercurrent rinsing is preferred, following cyanide processes, since low contamination of cyanide residual is essential in the final rinse to minimize cyanide drag-in to subsequent processes and to protect operators while handling parts. A cyanide residual of <5 ppm is recommended. Countercurrent rinsing will also reduce water usage significantly and reduce the life cycle costs of wastewater treatment, recycling and/or recovery systems. Figure 1 shows countercurrent rinsing.

Optimizing operating practices, as listed in Appendix A, can reduce process and wastestream problems significantly. See Appendix B for Best Management Practices for treating cyanide-based plating processes.

### Recovery Technologies

Vacuum evaporation, reverse osmosis and ion exchange have all been used very effectively to recover cyanide-based process drag-out and/or to recycle rinsewater. However, effective use of these technologies with cyanide wastewater requires some special considerations.

### Vacuum Evaporation

Vacuum evaporation (VE) has been used extensively to concentrate cyanide-bearing rinsewater to recover solution dragout. The distillate is normally reused as rinsewater. The principle problems associated with the application of VE to cyanide-bearing rinsewater are fouling of heat exchangers due to scaling and precipitation of solids and pass-through of cyanide in the distillate. The first problem can be partially controlled by process solution maintenance to control particulate and carbonate levels in the process solution (and therefore the rinsewater) and through prefiltration of the evaporator feed. In addition, the operat-

ing temperature must be controlled to avoid decomposition of cyanide and the maximum concentration of the concentrate stream must be controlled to avoid precipitation of solids. The second problem requires selection of an evaporator with a well-designed separator to control carry over of cyanide in the condensate (distillate). Figure 2 shows a process that uses natural evaporation.

### Reverse Osmosis

Reverse osmosis (RO) has also been used extensively with cyanide-bearing rinsewater. RO is also sensitive to fouling and requires prefiltration to less than one micron. Ultrafiltration (UF) is often used as an effective prefilter in this application. Membranes that are more resistant to fouling have been developed; however, effective prefiltration is the best assurance for efficient RO performance in cyanide applications. Since the concentration of the RO permeate is largely a function of the concentration of the RO feed stream, the RO permeate may not be suitable for use as makeup water in the final rinse. This problem can be avoided through proper sizing of the RO system to ensure an adequate rinsewater flow rate and an optimized feed concentration. Figure 3 uses RO or vacuum evaporation to recover rinsewater.

### Ion Exchange

Ion exchange (IX) has been used most often with precious metal plating (silver and gold) and requires a special configuration to recover the strongly complexed metal cyanides. IX is commonly used in surface finishing to recover metal and recycle rinsewater and is typically used in a cation-anion configuration. Cations are the cation resin (typically strong acid) and anions, including free cyanide, are captured on the anion resin (typically strong base). The strong acid resin will break the weakly bound cyanide salts of sodium, potassium, cadmium, copper and zinc. Silver and gold plating applications require an anion-cation-anion configuration and the metal cyanide complex is then bound to the leading anion exchanger. The silver- or gold-bearing anion resin is generally sent off-site for recovery. Other anion resins may be regenerated with NaOH. The subsequent dilute, metal-free cyanide stream may be concen-

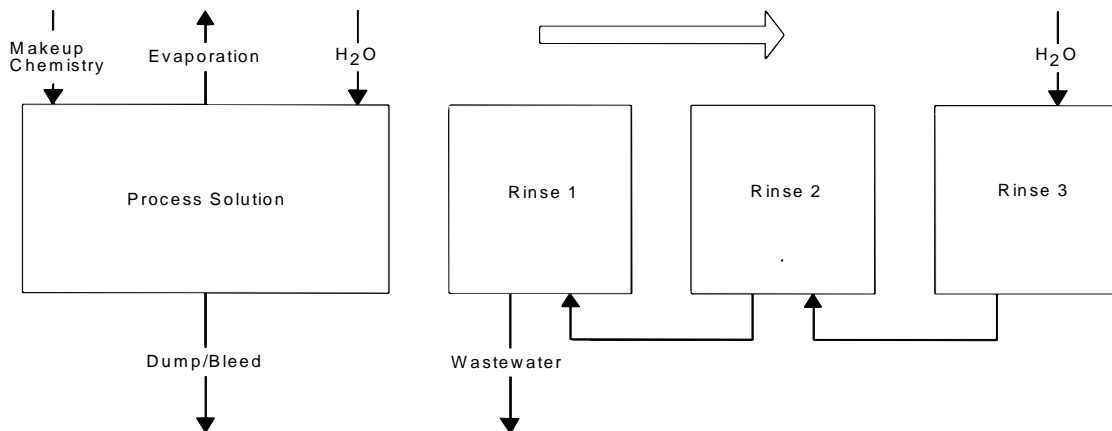

**Figure 1.** Open process showing solution maintenance using periodic dump or bleed and countercurrent rinsing with a continuous wastewater discharge.

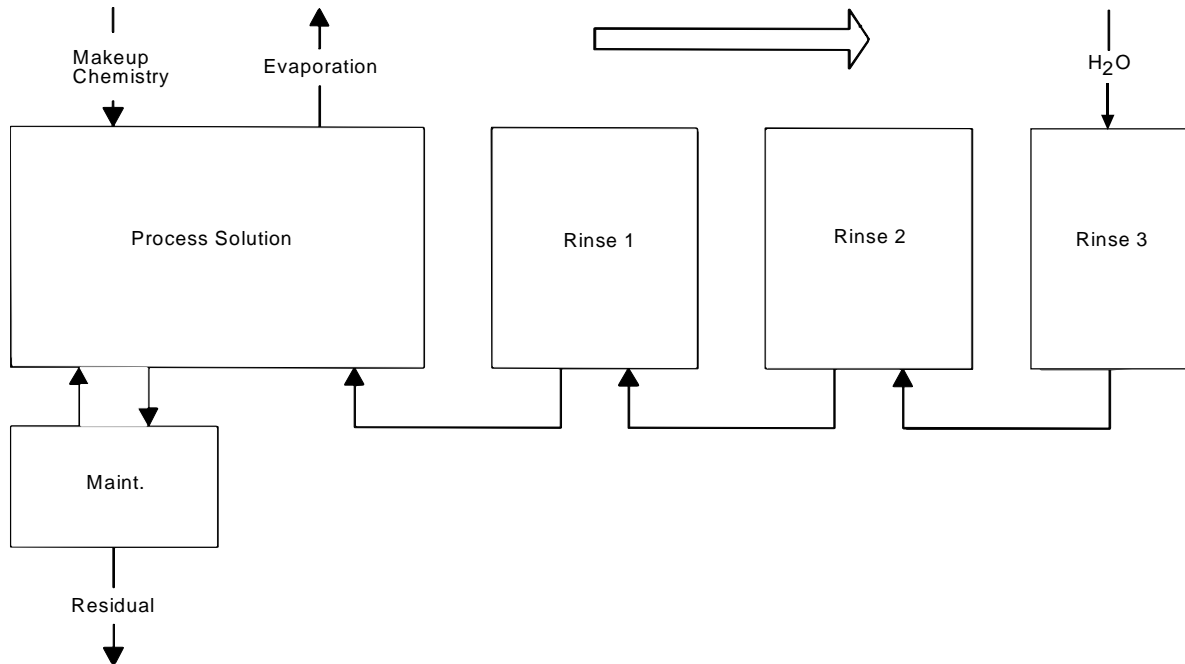

**Figure 2.** Closed-loop process showing continuous solution maintenance and rinsewater recovery with natural evaporation.

trated for reuse or treated for discharge. The cation resin may be regenerated on-site with sulfuric acid. The metal may be recovered with electrowinning. In either configuration, the rinsewater may be recycled as rinsewater makeup. Figure 4 shows a process that uses ion exchange and electrowinning.

IX resins are highly sensitive to fouling from precipitates and, like other technologies, prefiltration is important. Organic components in the feed stream can also foul resins. Granular activated carbon (GAC) is often used before IX

to control organics. IX system design also requires consideration to avoid mixing of cyanide and acids.

### Electrowinning

Electrowinning or electrolytic metal recovery (EMR) has been used extensively on cyanide-bearing rinsewater to recover metal and to destroy cyanide *in situ*. Electrowinning is not capable of recycling rinsewater; however, it can minimally reduce water usage. It is an important secondary technology that can be deployed with ion exchange, as described above.

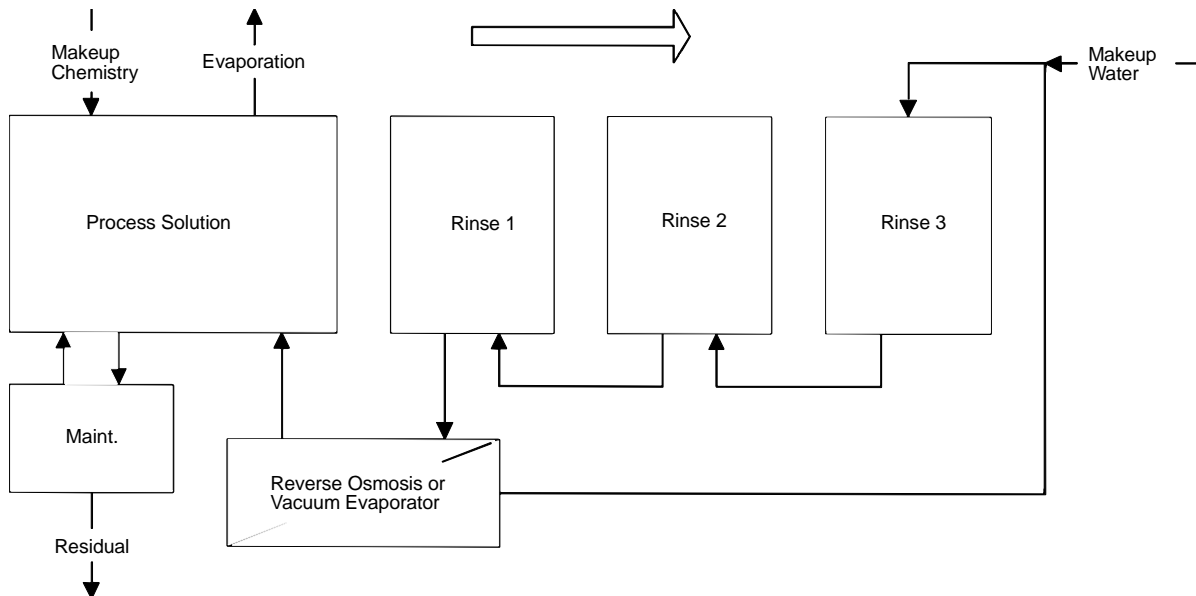

**Figure 3.** Closed-loop process showing continuous solution maintenance and rinsewater recovery with reverse osmosis or vacuum evaporation.

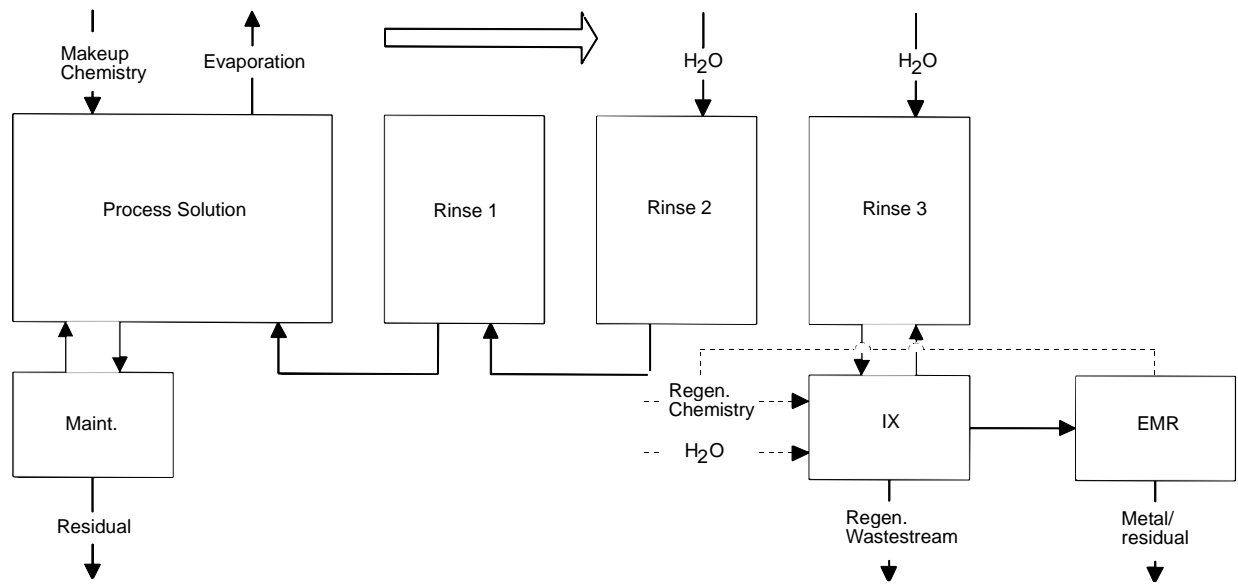

**Figure 4.** Open-loop process showing continuous solution maintenance and rinsewater recovery with natural evaporation and ion exchange/electrowinning.

## 7.0 Cyanide Alternatives

Non-cyanide-based surface finishing processes have become increasingly important to the industry. At present, over 70% of zinc plating is produced from non-cyanide plating chemistry (Hajdu, 1999). Non-cyanide copper plating is significantly more common than cyanide copper plating, even though cyanide copper plating remains an important process for preparing substrates for further plating. Non-cyanide cadmium- and indium-plating processes have been developed; however, the cyanide-based processes remain the dominant chemistry. Non-cyanide silver- and gold-plating processes have also been developed but are not generally well accepted. Effective substitutes for cyanide-based brass, bronze, silver and gold processes, as well as less common plating processes, are still in development. Table 6 provides an overview of cyanide and non-cyanide plating processes.

Non-cyanide alkaline descaling and metal stripping processes are common and utilize other metal complexers such as EDTA. Despite the effectiveness of cyanide-based cleaners and strippers there are very few situations that favor cyanide use in cleaning and stripping.

**Table 6.** Cyanide and Non-cyanide Plating Processes

Metal	Cyanide	Non-cyanide
Brass	Proven	No
Bronze	Proven	No
Cadmium	Proven	Yes
Copper	Proven	Proven*
Gold	Proven	Developing
Indium	Proven	Yes
Silver	Proven	Developing
Zinc	Proven	Proven

\* New alternatives in development for specific cyanide processes.



## 8.0 Cyanide Monitoring and Analysis

### Wastewater Compliance Monitoring

A well-designed and operated facility can handle cyanide safely and avoid exposure to workers, but it may encounter compliance problems, usually concerning wastewater discharges. There are two components to the cyanide discharge: the total cyanide concentration and the quantity of cyanide amenable to chlorination. The amenable cyanide is a measure of the effectiveness of the cyanide destruction system in treating free cyanide and metal complexes amenable to alkaline chlorination. As previously noted, complexed iron cyanide is not destroyed by alkaline chlorination. Nickel and silver cyanide require extensive retention times and excess chlorine dosage beyond stoichiometric. Discharge levels for total cyanide are very low, in the range of 1-2 ppm, depending on state regulations, and are usually measured at the point of treatment rather than at the point of discharge. Residual chlorine concentrations are usually controlled at  $\leq 10$  ppm.

Many operations are permitted on the basis of amenable cyanide rather than total cyanide for wastewater discharges. This alternative compliance method requires less than 1 ppm amenable cyanide and requires an additional laboratory test; however, the standard is generally much easier to attain and can be achieved with conventional technology. Challenges to the use of the amenable cyanide approach include difficulties with the sample analysis procedures established by USEPA.

There are three official methods for wastewater compliance monitoring: ASTM D 2036 Method B, EPA Method 355 and *Standard Methods for the Examination of Water and Wastewater*, 19<sup>th</sup> Edition, Method 4500-G (1995). Each allows the use of slightly different procedures and equipment. Varying levels of residual chlorine are possible with the procedures (Altmayer, 1997), and since the complexed cyanide is in equilibrium with free cyanide, aging samples with residual chlorine shows a marked decrease in cyanide concentrations (ASTM, 1998). In addition, sulfides and thiocyanate, which are common chemicals found in metal finishing wastestreams, can interfere with the analysis. The main point of difficulty is that a separate test must be used to determine the cyanide amenable to chlorination, and a variety of experimental errors and method imprecision can lead to a non-compliance determination. An alternative method currently under consideration is the "Modified Roberts-Jackson Method for Analysis of Simple Cyanides" (Altmayer, 1997). A facility can petition the lo-

cal regulatory authority to use this method as an alternative.

### Cyanide Analysis

Potential compliance problems can be compounded as a result of several analytical methods being used, which can vary from laboratory to laboratory. Methods used depend on the character of the cyanide compounds in the waste, their concentration and the presence of interfering agents. In addition, the laboratory procedures allow the use of steps which can make comparison of results difficult. Understanding the basics of the laboratory analyses for cyanide can assist a facility in maintaining better compliance of the operation and control of cyanide plating processes. This section covers the laboratory analyses used to determine cyanide concentrations in wastewater, the conditions where difficulties arise and a new technique for determining cyanide in wastewater, proposed in the *Federal Register* in 1998.

The accepted methods currently in use for cyanide analysis in wastewater are EPA method 335; Method 4500 G, *Standard Methods for the Examination of Water and Wastewater*, 19<sup>th</sup> Edition (Standard Methods); ASTM D 2036 Method B. The new method is EPA Method OIA-1677. In general, the methods are most effective with cyanide species that fully dissociate. These include cadmium and zinc. Some of the species only partially dissociate and are not fully recovered. Cyanide complexes in this category include copper, nickel, silver and mercury complexes. Some cyanide complexes do not dissociate appreciably and are not measured effectively using these techniques. The cyanide compounds in this category include the more noble metal complexes, including gold, platinum and cobalt. All of the methods are subject to interference; controlling the interfering sources is key to consistent results. Minimal detection limits range from 0.005 mg/L for colorimetric cyanide determination to 0.4 mg/L by titration.

Most methods are sensitive to sulfides and thiosulfate. These compounds can lead to the formation of hydrogen sulfide gas, which is collected with hydrogen cyanide gas and interferes with measurement of the cyanide present. Many organic compounds can also interfere, including fatty acids, sugars and aldehydes. Fatty acids form soaps during the distillation process, making determination of the endpoint difficult. Aldehydes and sugars react with cyanide to form cyanohydrin, a compound not detected as cyanide. In addition, the presence of oxidizers can de-

destroy the available cyanide. Sunlight and ultraviolet radiation break down cyanide; all of the procedures contain steps to shield the samples from sunlight. Dilution of the samples can lead to erroneous results as the dilution allows for new equilibrium conditions to form and can effect the cyanide available for chlorination. Typically, dilution can result in falsely inflated values for amenable cyanide.

Another key aspect of the available cyanide is the determination of excess chlorine during chlorination. Excess chlorine is removed prior to cyanide analysis and is usually monitored with potassium iodide starch test papers. A color change occurs in the presence of excess chlorine. The starch test papers are not precise and can err by a few ppm in the actual quantity of chlorine present, but are an excellent qualitative indicator. All cyanide analytical methods include steps to track and treat chlorine residual. However, the methods differ on the amount of excess reagent necessary to achieve chlorine removal, and the condition can actually result in some residual chlorine. The residual chlorine reacts with cyanide during the cyanide analysis in the gas scrubber to destroy additional cyanide and can lead to inflated results for available cyanide.

#### “Standard Methods,” Method 4500-G

In this method, the wastewater sample is split into two parts. The samples must measure 500 ml and may be diluted to obtain this volume. One split is evaluated for total cyanide. The second split is chlorinated to destroy the available amenable cyanide and then evaluated for to-

tal cyanide. The difference between the two samples is expressed as amenable cyanide. The chlorination reaction is run for one hour with agitation at high pH (11-12). A chlorine residual of 50-100 ppm is maintained and the residual is monitored with potassium iodide test papers, which turn blue in that concentration range. Following the reaction, the excess chlorine is removed by the addition of sodium arsenate or by the combination of hydrogen peroxide and sodium thiosulfate. The chlorine residual is tested with potassium iodide starch papers. Chlorinated and unchlorinated sample portions are then distilled using the apparatus shown in Figure 5. Only samples containing less than 10 mg/L cyanide may be tested this way. If higher concentrations are expected, the sample must be diluted. During the distillation, the dissolved cyanide is converted to hydrogen cyanide gas by acidification and captured in the gas dispersion tube. This tube contains an alkaline solution to capture the cyanide gas. This sample is treated with chloramine-T, forming cyanogen chloride and changing to a red-blue color by the indicator. The color intensity is then measured colorimetrically to determine the cyanide concentration.

Dilution can effect the concentration of cyanide detected by allowing the equilibrium between the free and complexed cyanide to be adjusted, releasing additional cyanide. In addition, potassium iodide test papers may not detect a few ppm chlorine. This condition can lead to additional destruction of cyanide during the distillation step. An excess of reducing reagent is required to destroy excess

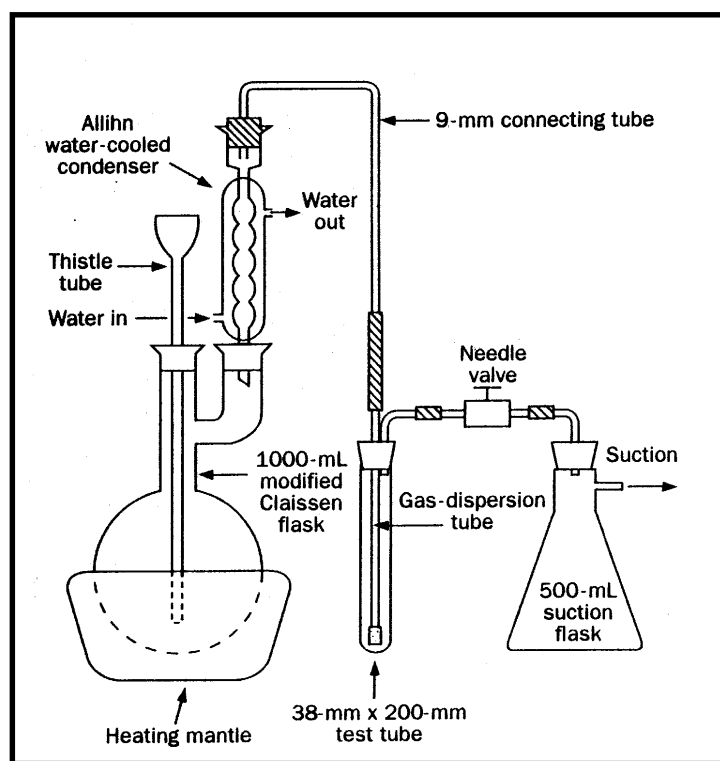

Figure 5. Distillation apparatus for evaluating cyanide samples.

chlorine to ensure a true determination of the amenable cyanide.

### EPA Method 335 Cyanide Amenable to Chlorination

This method is similar to "Standard Methods" method 4500-G. The wastewater sample is divided into two portions. One is tested for total cyanide. The other is chlorinated to destroy the amenable cyanide and then tested for total cyanide. The difference between the two concentrations is the cyanide amenable to chlorination. Depending on the cyanide concentration, this test is either accomplished by titration or spectrophotometry. Like the "Standard Methods," the extent of chlorination is monitored with potassium iodide starch papers. After chlorination, the excess chlorine is removed by the addition of ascorbic acid, and the removal is checked with the potassium iodide test papers. Unlike the "Standard Methods," an excess of ascorbic acid is necessary if a negative test for chlorine is detected with the starch test papers.

The sample volumes must be 500 ml and can be diluted to reach that volume. Dilution can affect the concentration of cyanide detected (Altmeyer, 1997) by allowing the equilibrium between the free and complexed cyanide to be adjusted, releasing additional cyanide. The concentration determined in the original sample includes the dilution factor, an effect which sometimes results in inflated amenable cyanide concentrations. In addition, the method is susceptible to several interferences, many of which result in inflated values of amenable cyanide.

### ASTM D 2036 B

This method is similar to the previous two. Amenable cyanide is again determined as the difference of two measurements. Sample size is 500 ml for the determination of the total cyanide and the cyanide amenable to chlorination. Dilution of the sample is allowed either to make up for insufficient volume or to reduce the total cyanide concentration. Removal of excess chlorine is accomplished with

sodium arsenate and hydrogen peroxide. Each of the two samples are then analyzed for total cyanide using the same distillation procedure previously described.

### EPA Method OIA-1677

This method uses a two-step process: the sample is pre-treated, then injected into the cyanide detection cell. Pre-treatment consists of mixing the sample with ligand exchange reagents, forming stable complexes of the transition metals present, and releasing the cyanide from the original complexes in the sample. Detection makes use of a flow injection analysis shown schematically in Figure 6. In the flow system, hydrochloric acid reacts with the injected sample to release hydrogen cyanide gas, which passes through the gas-permeable membrane. The gas is recaptured on the detector side of the membrane with an alkaline solution that converts the hydrogen cyanide gas back to dissolved cyanide ion. The cyanide concentration affects the current of the electrode system, made up of a silver working electrode, a silver/silver chloride reference electrode and a platinum/stainless steel counter electrode. The current change is proportional to the cyanide concentration. Analysis time is less than five minutes.

This test was proposed in the *Federal Register* in the fall of 1998. The technique has several advantages over the different techniques currently used, including reduced processing time and its ability to fully recover cyanide from complexes that only partially dissociate. This includes the nickel silver and mercury cyanide complexes. Like the other techniques, it is unable to process extremely stable complexes. The flow analysis system must be calibrated regularly, and the apparatus is expensive. Expense is important because this technique is not being proposed as a replacement for the other techniques, but, rather, it is intended to augment the existing techniques. Therefore, many laboratories may choose not to include this technique until it has been further proven.

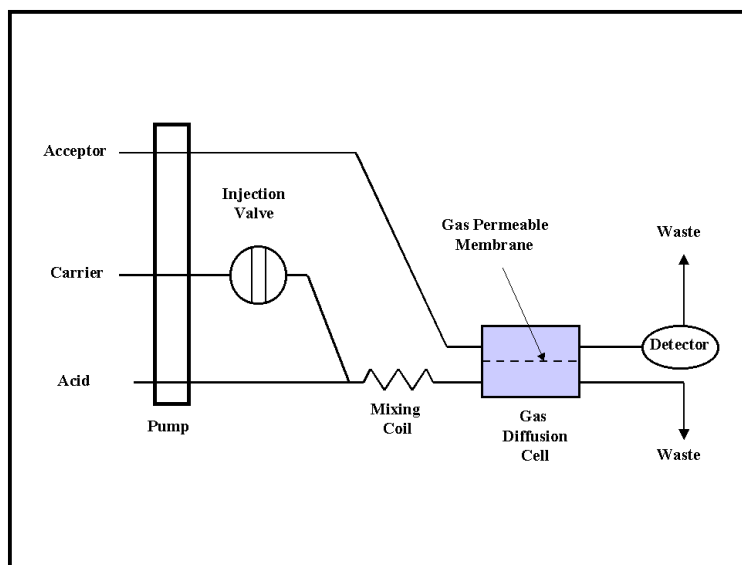

Figure 6. Flow injection analysis schematic.

## 9.0 Summary

A well-designed and operated facility can handle cyanide safely and protect its workers, manage cyanide-bearing wastestreams and enjoy the benefits of cyanide-based processes. Clearly, some non-cyanide process alternatives provide surface finishing facilities with significant advantages in specific circumstances. However, non-cyanide processes are often more difficult to treat in conventional wastewater treatment systems, more difficult to recover or recycle and are, generally, more difficult to control. Cyanide use requires careful management, thorough operator training and proper facility design.

Similarly, it is important for the regulatory community to address deficiencies that exist in compliance testing. Cur-

rent protocols can lead to unwarranted additional sampling, testing and corrective action. Improved analytical methods for detecting cyanide in wastestreams need to be explored.

While many facilities have already phased cyanide out of their operations, other facilities have retained cyanide use and have assumed responsibility for its control. It is likely that effective non-cyanide alternatives will continue to be developed to provide users with new alternatives in the future. However, for those facilities that continue to use cyanide, rigorous adherence to best management practices and effective use of technology are essential.

## References

### Section 1.0

1. *Development Document for Existing Source Pretreatment Standards for the Electroplating Point Source Category*, EPA Document No. 440/1-79/003. USEPA. August 1979.

### Section 2.0

2. *Modern Electroplating*, 2<sup>nd</sup> Edition. Lowenheim, F.A., ed. John Wiley & Sons. NY, NY. 1953.
3. *AESF Electroplating Course*. Schwartz, M. and D. Swalheim. AESF. Orlando FL. 1996.
4. *Treatment of Metal Waste Streams*, 1<sup>st</sup> Edition. California State University. Sacramento, CA. 1990.
5. *Lange's Handbook of Chemistry*, 13<sup>th</sup> Edition. Dean, J.A., Ed. McGraw-Hill. 1985.

### Section 3.0

6. *Dangerous Properties of Industrial Materials*, 7<sup>th</sup> Edition. Sax, N.I. and R.J. Lewis. VanNostrand Reinhold. NY, NY. 1989.
7. *Development Document for Existing Source Pretreatment Standards for the Electroplating Point Source Category*, EPA Document No. 440/1-79/003. USEPA. August 1979.
8. *The Merck Index*, 11<sup>th</sup> Edition.
9. *Electroplating*, AP-42, Section 12.20. July 1996.

### Section 4.0

10. *Managing Cyanides in Waste Discharges*. Menne, D.M. <http://users.wantree.com.au/~menne/cnmanage.htm>. May 1997.

### Section 5.0

11. *Handbook of Effluent Treatment and Recycling for the Metal Finishing Industry*, 2<sup>nd</sup> Edition. Hartinger, L. Finishing Publications. 1994.
12. *Industrial Wastewater Treatment Technology*, 2<sup>nd</sup> Edition. Patterson, J.W., Butterworths. 1985.

13. *Chemical Processes in Wastewater Treatment*. Eilbeck, W.J. and G. Mattock. Ellis Horwood Limited. 1987.
14. *Cyanide Destruction: The Inco SO<sub>2</sub>/Air Process*. INCO. Inco Exploration and Technical Services. 1993.
15. *Plating and Surface Finishing*, "Chasing Those Elusive Cyanide Ions." Martin, T.H. AESF. Orlando, FL. November 1992.

### Section 7.0

16. *AESF SUR/FIN 99 Proceedings*. "Cyanide Replacement in Zinc Plating: A Case History." Hajdu, J. June 1999.

### Section 8.0

17. Altmayer, 1997
18. *Standard Methods for the Examination of Water and Wastewater*. 19<sup>th</sup> Edition. Amer. Pub. Health Assn. Washington, D.C. 1995.
19. *Annual Book of ASTM Standards, Method D 2036*. ASTM. 1998.
20. *Federal Register*. Vol 63, No. 129, Proposed Rules, pp 36809-36824. July 1998.

### Additional References

21. *Operation and Maintenance of Surface Finishing Wastewater Treatment Systems*. Roy, C.H. American Electroplaters and Surface Finishers Society. 1988.
22. *Principles of Industrial Wastewater Treatment*. Gurnham, C.F. John Wiley & Sons. 1955.
23. *Industrial Water Pollution Control*, 2<sup>nd</sup> Edition. Eckenfelder, W.W. Jr. McGraw-Hill. 1989.
24. *Plating and Surface Finishing*, "Advice & Council," Altmayer, F. AESF. Orlando FL. February 1997.
25. *Handbook of Chlorination*. White, G.C. Van Nostrand Reinhold. NY, NY. 1972.

## Appendix A

### Optimizing Operating Procedures

Good operating procedures can reduce process operating and wastestream problems significantly. While cyanide processes are relatively tolerant compared with many alternative surface finishing processes, good process control is always cost effective over the long term.

Good operating practices for use with cyanide-based processes include the following:

- Use countercurrent rinsing to improve rinsing effectiveness and reduce water usage and wastewater generation. Three rinse stages are generally most effective with cyanide-based processes. Countercurrent rinsing may also reduce wastewater flow sufficiently to facilitate batch treatment of wastewater.
- Establish water and rinsewater quality standards. A cyanide residual of <5 ppm is recommended in the final process rinse. Makeup water quality can affect process and product quality as water-based contaminants accumulate in the process. Chloride, fluoride, iron, copper, zinc and lead, as well as other heavy metals, can lead to various process problems. Deionized water is recommended for solution makeup and for rinsewater makeup in closed-loop processes.
- Control drag-in of chlorides, iron and other contaminants from preplate processes by setting rinsewater quality standards for these processes. Use countercurrent rinsing to improve rinsing effectiveness and minimize water use.
- Use drag-out or rinsewater recovery; it is cost effective with many cyanide-based processes. Closed-loop rinsing may reduce or eliminate the need for cyanide pretreatment.
- Solution maintenance should incorporate control of contaminants, including particulates, organics, metals and carbonates. Concentration limits should be set for contaminants, and analytical control procedures should be set to monitor contaminants as well as makeup chemicals. Solution dumps and/or bleeds should be based on contaminant build-up and not on a simple time basis.
- Don't use cyanide-based plating processes as cleaner and plating solution. Parts should have a water break-free surface prior to plating.
- Segregate cyanide wastestreams from other wastestreams for wastewater treatment or off-site disposal.
- Avoid air agitation or any other aeration of cyanide solutions.

## Appendix B

### Best Management Practices

**Best management practices for cyanide include the following:**

- Develop a cyanide management plan, and integrate it with the facility environmental and safety management plan.
- Establish initial and refresher cyanide management training for managers, workers and contractors.
- Establish well-defined personnel responsibilities and clear chains of command for cyanide use and management.
- Develop safe procedures for handling cyanide, i.e., storage, transportation, containment, spill management, production processes, raw material additions, solution sampling and analysis, solution maintenance, waste treatment, waste disposal and equipment maintenance.
- Develop rinsewater quality standards for all cyanide processes and pre-cyanide processes. Generally 5 ppm is a reasonable rinsewater standard for a final cyanide process rinse.
- Develop and implement an integrated pollution prevention strategy encompassing point source waste minimization, recovery, and recycling, waste treatment and off-site disposal.
- Conduct regular cyanide audits, with corrective action, and update the cyanide management plan on a regular basis.
- Maintain primary containment tanks, drums, piping, valves, pumps and other equipment to prevent leaks and spills.
- Segregate cyanide processes, pretreatment, storage and other operations from non-cyanide operations in a separate secondary containment system.
- Store cyanide-based raw materials in a secure, dry and ventilated storage area.
- Monitor work areas for hydrogen cyanide and wastewater treatment areas for hydrogen cyanide and cyanogen chloride
- Ventilate all cyanide process, wastewater treatment and storage areas
- Provide workers and visitors with proper protective equipment including gloves, aprons, face shields, goggles, safety glasses, respirators and other protective clothing.
- Provide workers and visitors with access to lavatories and showers to maintain appropriate personal hygiene.
- Dispense and weigh raw materials in a ventilated area.
- Develop and practice emergency procedures for cyanide spills.
- Develop and practice emergency procedures for human exposure (skin, eye, ingestion) to cyanide mists and fumes.
- Use the minimum amount of cyanide required for adequate process or operation.
- Avoid air agitation of cyanide solutions as carbon dioxide can liberate hydrogen cyanide. (see page 13).